

Dim.	Tolerance	Angular tolerance	Surface finish	Rev	Date	Description	Name
X	$\pm 0,2$	$\pm 1^\circ$	Ra 5	1			
XX	$\pm 0,1$	$\pm 0,5^\circ$	Ra 2,5	2			
X.XX	$\pm 0,05$	$\pm 0,2^\circ$	Ra 1,25	3			
				4			
				5			
				6			

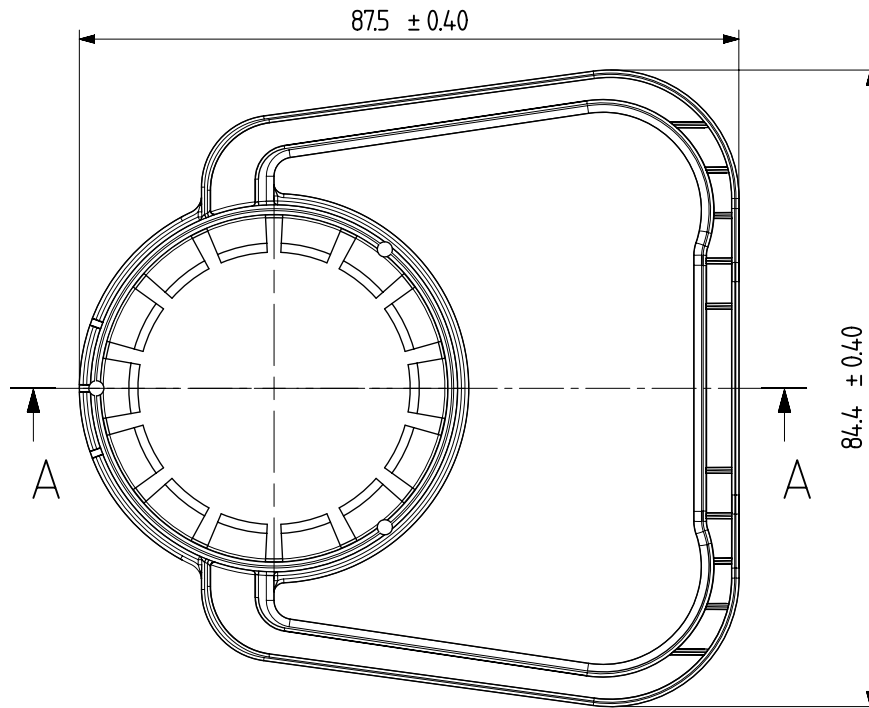
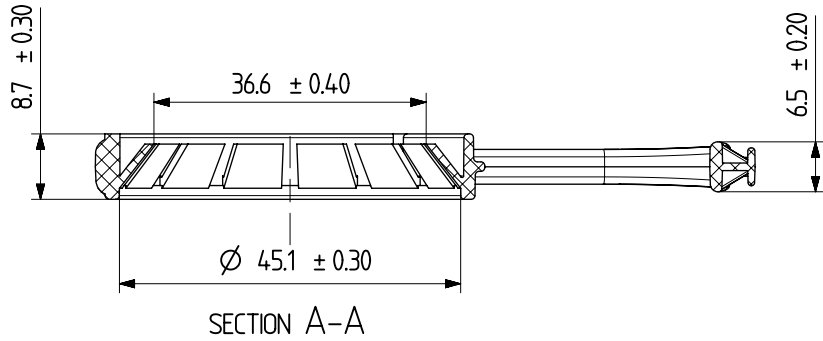
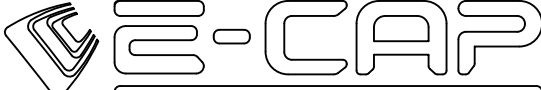

Massa  $5.4 \pm 0.5$  g

1	Handle RPB 38	1	HDPE	5.8 cm <sup>3</sup>		Scale	Format
No	Part name	Qty	Material/Supplier	Volume	Remarks	1:1	A4
Design		Project name			Project number		
Drawing	A.Nesterovich	Handle RPB 38			Mold 18		
Approved	A.Leibutin	Part number					
	Name	Date					
			RPB_38				