

SECTION A-A

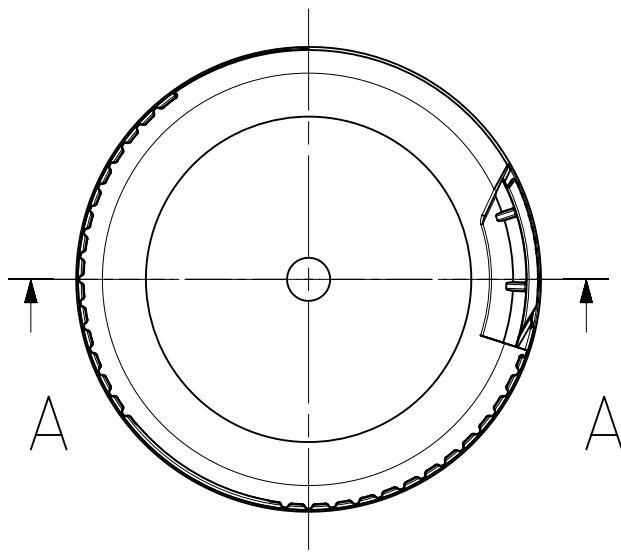

Massa:  $1.76 \pm 0.30$  g

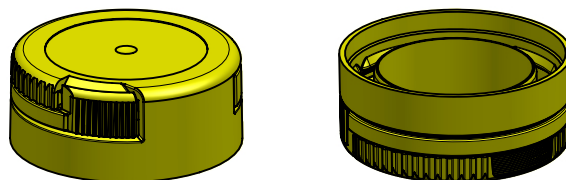

Scale 1:1

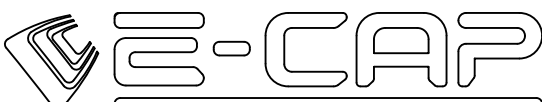
1	POP 29	1	LDPE	1.95 cm <sup>3</sup>			
No.	Part name	Qty	Material/Supplier	Volume	Drawing number	Remarks	
Design	D.Samusev	13.07.2020	Project name				
Drawing	D.Samusev	13.07.2020	POP 29				
Approved	A.Leibutin	13.07.2020					
	Name	Date	Project number			Scale	Format
			PF-026/16			2:1	A4