

Rev	Date	Description	Name
1			
2			
3			

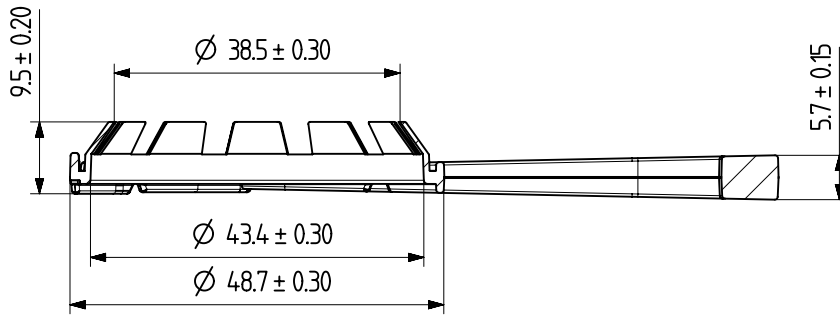

SECTION A-A

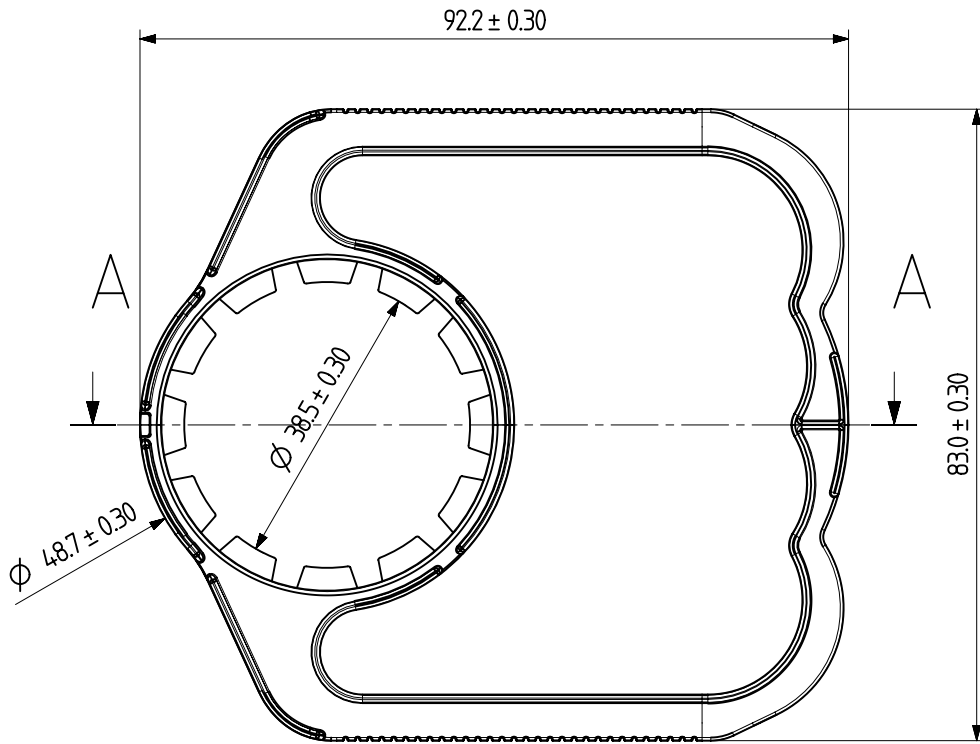
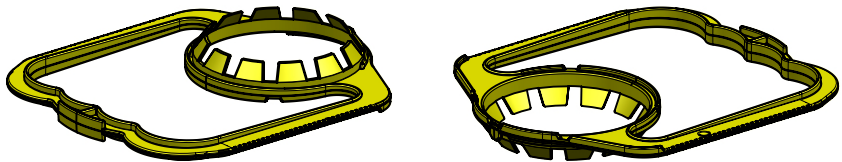

Massa: 4.5 ± 0.30 g.

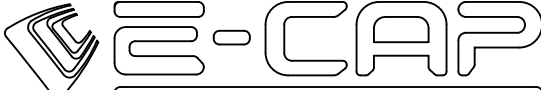
1	Handle 38mm.	1	HDPE	4.95cm ³		for automatic line	
No.	Part name	Qty	Material/Supplier	Volume	Drawing number	Remarks	
Design	D.Samusev	24.04.2020	Project name				
Drawing	D.Samusev	24.04.2020	RPB 38				
Approved	A.Leibutin	24.04.2020					
	Name	Date	Project number			Scale	Format
			PF-025/4			1:1	A4